

FONTANA SIERRA GOOSE NECK COMMERCIAL AUTOMATIC OIL RUBBED BRONZE SENSOR FAUCET SPECS

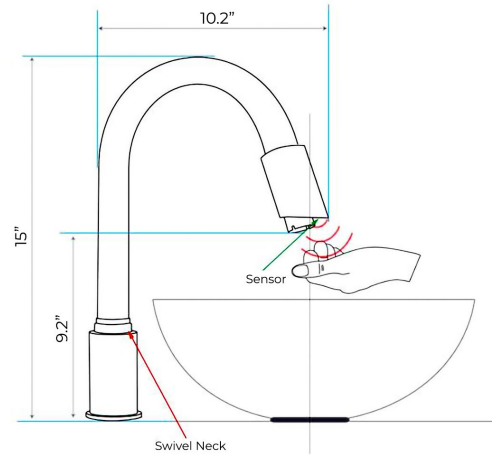

SPECS :

Power: DC:6V(4AA alkaline battery)

AC:220V-240V; 50/60HZ

Temperatural adjustable 0 °C ~ 60 °C

Detection Zone: 16-32 cm or adjustable

Motor valve lifespan: up to 500000
flushes

Battery lifespan: 100000 cycles

Static Power Consumption: 0.36mw

Working Power consumption: 0.5mw

Inductive Opening Time: < 1 second

Inductive Closing Time: < 2 second

Dia.of inlet / outlet pipe: G1/2"

Infrared sensor operation

Flow Rate: 1.3 GPM

(gallons-per-minute)

Maximum Deck Thickness: 1-5/8"

